



BBQ Trolley

Written and constructed by Craig Tilley

This trolley makes a very handy outdoor barbecue trolley. It's also a great showpiece and functional drinks tray for the patio when entertaining. The timber used is western red cedar which is very durable and suitable for many years of outdoor use, provided it is regularly maintained.

If the trolley is for outdoor use, ensure waterproof glue is used throughout the construction. If only for use indoors a good quality PVA will be best and an alternative timber can be used. The top tray features a handy cutlery and utensil bin and the bottom tray incorporates a convenient bottle holder. Finish the trolley with wood stain or an outdoor finish of your choice.

Component Specifications

All dimensions are in mm.

Part	Description	Quantity	Width	Thickness	Length
A	Frame sides (longer)	2	65	19	1100
B	Frame sides (shorter)	2	65	19	1080
C	Tray sides	4	65	19	683
D	Tray ends	4	65	19	480
E	Tray boards	16	65	19	480
F	Cutlery base	1	140	19	480
G	Tray dividers	2	46	19	480
H	Bottle holder	1	140	19	480
I	Handle	1	25 diam.		538
J	Wheels	2	240 diam.	19	

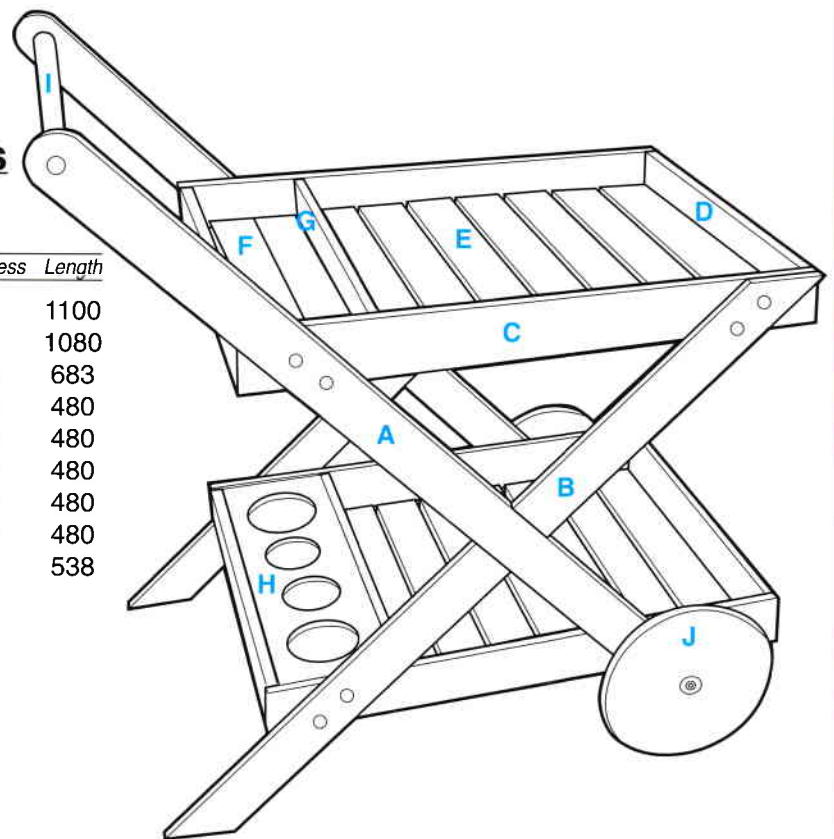

Tool Requirements

1. ESSENTIAL: Triton Workcentre with power saw, jigsaw, electric drill and drill bits, 25 mm spade drill bit, hammer, tape measure, tri square, screwdriver, nail punch, steel rule, glue brush, sanding block & sandpaper sheets, dust mask, eye goggles, ear muffs, pencil, file, chisel, C or F clamps, mallet.

2. USEFUL: Triton Sliding Extension Table, Drill press, Triton Multistand(s), Triton Dust Collector Bag, Triton Planer Attachment Kit, power plane, Triton Router & Jigsaw Table, router, 12.5 mm plug cutter, electric sander, large steel square

Construction details

Material Shopping List

1. WOOD

Western Red Cedar
75 x 25 - 6 @ 2.4 m
(65 x 19 finished) - 2 @ 2.7 m
150 x 25 - 1 @ 1.2 m (140 x 19 finished) for cutlery
base and bottle holder
250 x 25 - 1 @ 600mm (240 x 19 finished) for wheels
KD Hardwood dowel for handle
25 diameter - 1 @ 600mm

2. FASTENING

Waterproof glue (eg. Resorcinoll)
10G x 30 mm woodscrews - 16
40 mm galvanised bullet head nails
1/4" x 2 1/2" Coach Bolts - 2
Large Washers (OD = approx. 45mm) - 2
Small washers - 2
1/4" Hex Nuts - 4

3. FINISHING

Cedar colour wood filler and an outdoor finish of your
choice.

Cut the tray sides (C), tray ends (D), tray dividers (G) and tray boards (E) to length from the 65 x 19mm timber. Use the Workcentre in the crosscut mode.

The 2.7m lengths give five tray boards each. Two of the 2.4m lengths give three tray boards plus a divider each. Two of the other 2.4m lengths give the four tray sides and four tray ends.

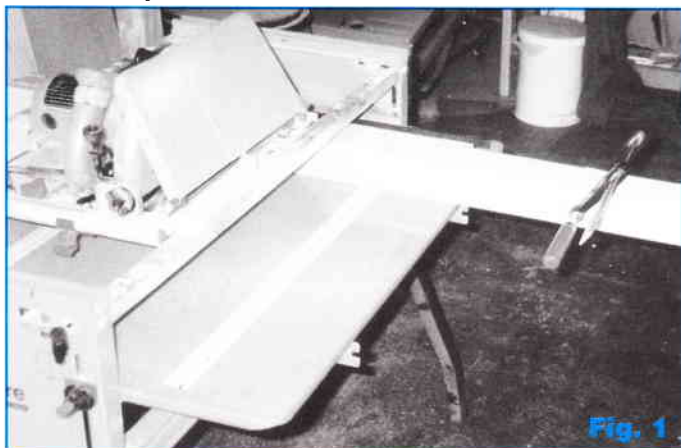

Identical length parts can be clamped together to ensure they come out the same length (Fig. 1). Sand all cuts smooth.

The long edges of the tray boards can be chamfered to a 45° angle using the 45° side of the Series 2000 Workcentre rip fence, in the tablesaw mode (Fig. 2).

Set the fence to 21 mm and make a trial cut on an offcut. When satisfied with the cut, chamfer the upper long edges of all the 65 x 19 tray boards.

Alternatively use the Bevel Ripping Guide set at 45°, or use an electric planer or router to bevel the edges.



Rip the two dividers (G) to a width of 46mm on the Workcentre in the tablesaw mode. Sand the cut edge smooth.

Mark and cut the 9mm deep rebates in the tray sides with two cuts on the Workcentre in the tablesaw mode.

For the first cut, set the saw blade to a height of 19mm and set the fence to 10 mm. If you have a Triton Height Winder Kit, setting up for accurate depth of cut is quick and easy. Test the cut first on an offcut.

When satisfied, make the cuts in the four tray sides for the joints with the tray boards, tray ends and bottle holder (Fig. 3).



The bottle holder (H) fits into stopped rebates, so make these cuts carefully and stop the saw before reaching the end of the rebate. A pencil mark on the timber will indicate when to stop the cut (Fig. 4).

Warning: The overhead saw guard will need to be removed to make the rebate cuts and halving joints throughout this project, so great care should be taken with your hand positions. Rehearse the cuts first with the power off and make sure your hands stay well away from the saw blade.

5 The second cut is made with the saw blade set at a height of 9mm and the fence set at 46 mm (Fig. 5). Again, make a test cut in the offcut first to check everything is right. Remember to make stopped cuts for the bottle holder joints.



For the end joints, use the protractor and the fence with a spacer as a stop (Fig. 6).

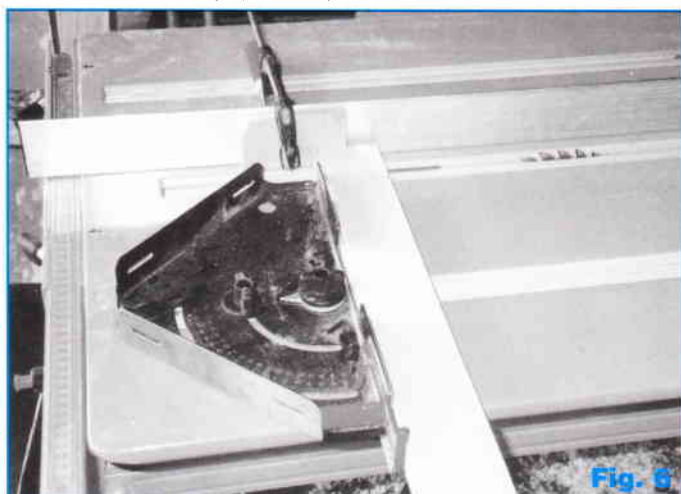

6 Make the rebates for the dividers by marking their position on the tray sides and using the protractor to make repeat cuts until all the waste is removed (Fig. 7).



Trim the bottom of these rebates with a chisel. Test all cuts for fit with the relevant pieces.

7 When all rebates have been cut and tested, glue and nail the trays together with waterproof glue and 40mm galvanised bullet head nails.

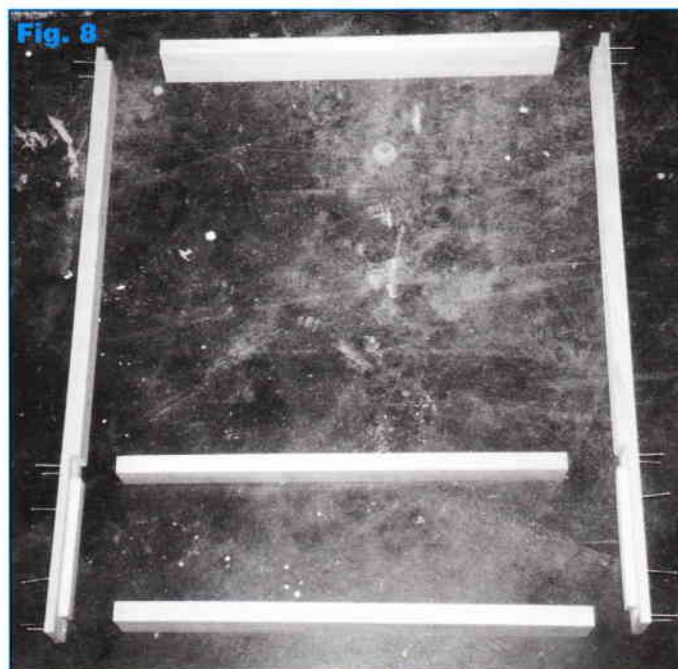

Attach the tray ends and divider first between the two sides (Fig. 8), then the tray boards in the bottom rebates (Fig. 9).

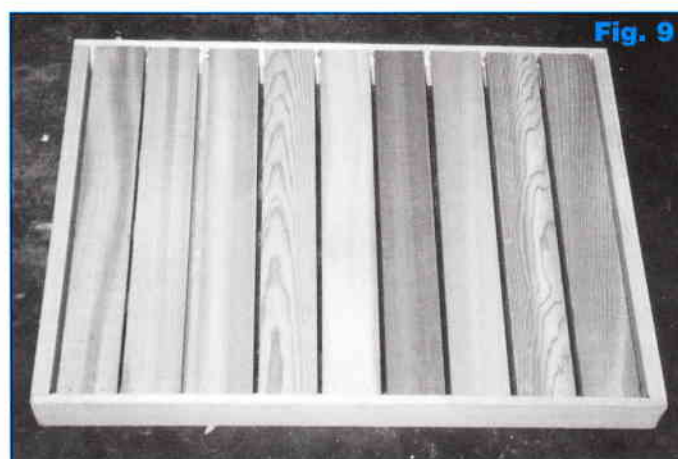

Note, the board (F) under the cutlery bin should be made from 140 x 19 mm so it is in one piece (Fig. 10).



All other boards are spaced with an approximate 6mm gap between them for drainage. Punch all nail heads slightly below the surface and fill with cedar colour wood filler.

8 Next, mark out a piece of 140 x 19mm for the bottle holder (H). Cut four holes for storing bottles upright on the bottom tray. **Fig. 11**.

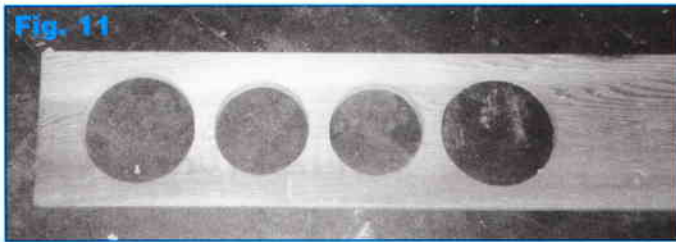

Mark out two circles 80mm in diameter and two 100mm in diameter for different size bottles. Use a compass to mark out the holes, or find a suitably sized paint tin and trace around the base of the tin. Space the holes equally along the length of the timber.

Drill a hole inside each circle so the jigsaw blade can be inserted and then cut out the circles with the jigsaw. Ensure the jigsaw blade stays on the inside of the marked lines.

Sand the cuts smooth and crosscut the piece to length on the Workcentre to fit neatly in the rebates along the bottom tray sides.

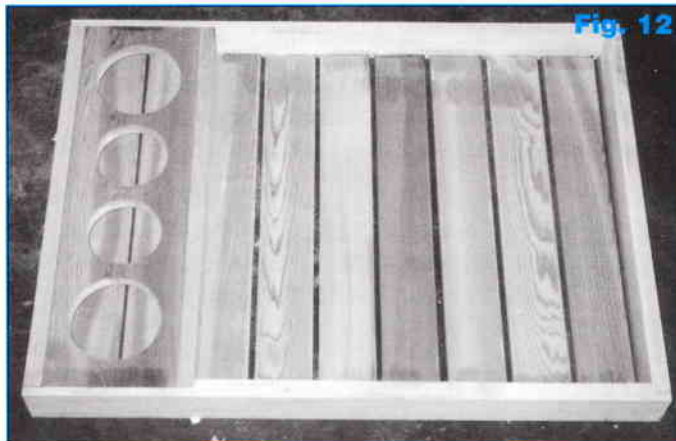

Glue and nail in place with 40mm galvanised bullet head nails (**Fig. 12**).

9 Mark out a 32.5mm radius on the ends of the longer frame sides (A). If you have a Triton Sanding Disc, fit it to the saw and use it to round over the ends. Alternatively, cut the curves with a jigsaw and sand them smooth.

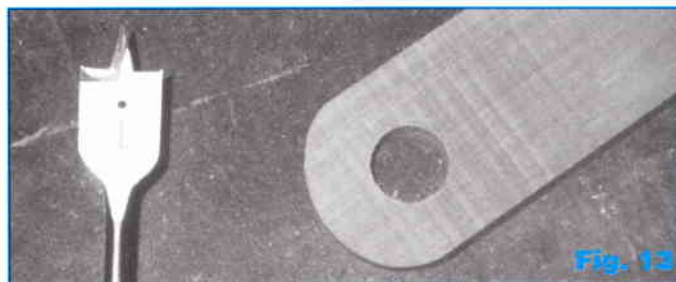

Clamp both the longer frame sides together and drill central handle holes with a 25mm (1") spade drill bit (**Fig. 13**). At the same time drill a 1/4" clearance hole centrally through both sides at the lower end for the axle bolts. Test that the 25 mm dowel fits snugly in its holes, and that the axle bolts fit easily through the axle holes.

10 Cut the shorter frame sides (B), longer than they need to be at this stage, using the Workcentre in the crosscut mode.

Cut the top end of the shorter frame sides in the tablesaw mode, against the protractor. Set the protractor to an angle of 48°.

Join one shorter frame side temporarily to the top tray with 10G x 30mm woodscrews, two per joint, counterboring the heads 5mm below the surface with a 12.7 mm (1/2") drill bit (**Fig. 14**).

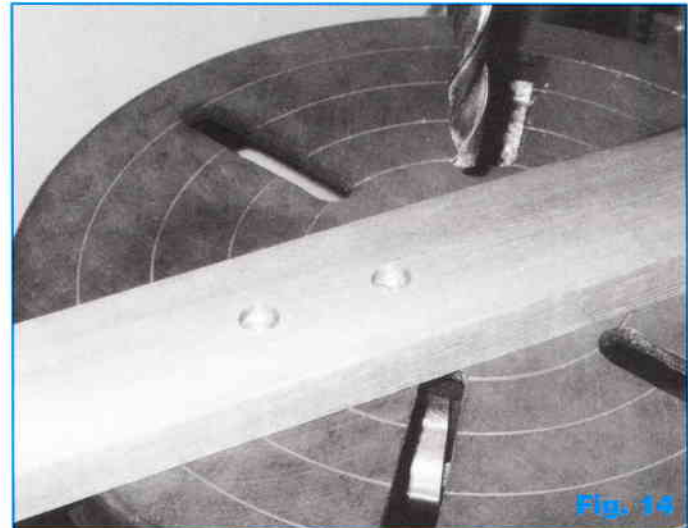

The screw heads will be covered with wood plugs (or dowels) cut from an offcut at a later stage. Position the bottom tray 400mm under the top one.

Measure at the front and back of the trays and ensure they are lined up and square to each other (**Fig. 15**).



Screw the shorter frame side to the bottom tray with two screws as before.

12 Lay one of the longer frame sides on top of the shorter one. The axle hole in the longer frame side should be clear of the bottom tray. Mark both pieces for the halving joint.

Adjust the position of the longer frame side until it forms an exact right angle with the shorter one. This means the halving joint will be cut at 90° to the timber edge which is much easier than an angled cut.

13 Lower the saw blade to half the thickness of the frame sides (i.e. a height of 9.5mm) and cut the halving joints against the protractor in the tablesaw mode. With the protractor set at 90° make repeat cuts until all the waste is removed from the joint (**Fig. 16**).

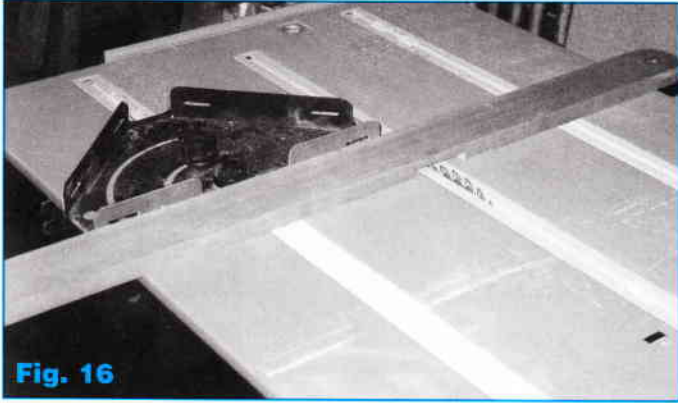

Smooth the bases of the halving joints with sandpaper.

14 Test the fit of the halving joint then reattach the shorter frame side to the trays and screw the longer frame side in place with 10G x 30 mm woodscrews, two per joint, counterboring the heads as before. (**Fig. 17**)

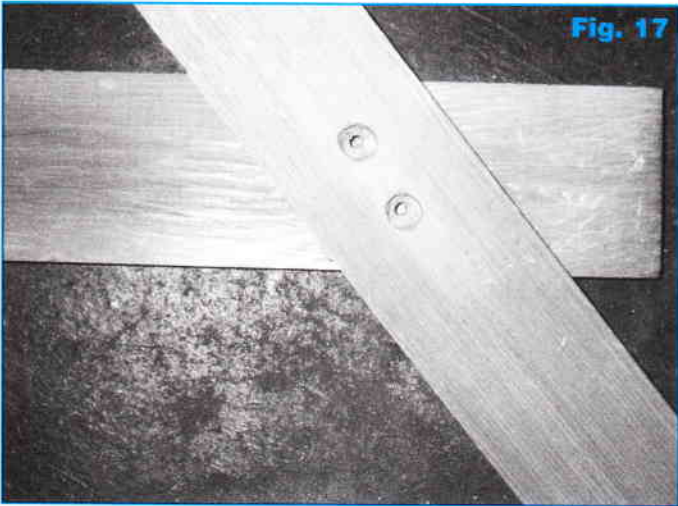

15 Repeat steps 11-14 for the other side of the trolley, ensuring the frame sides line up with each other, especially the handle and axle holes.

16 Cut the dowel handle to fit between the two longer frame sides

17 To mark out the 240 mm diameter for the wheels (J), use a scrap piece of wood. Drill a hole for a nail at one end and 120mm away drill another hole to hold a pencil (**Fig. 18**). Position the nail at the centre of the circle and push the wood around to mark the circle.

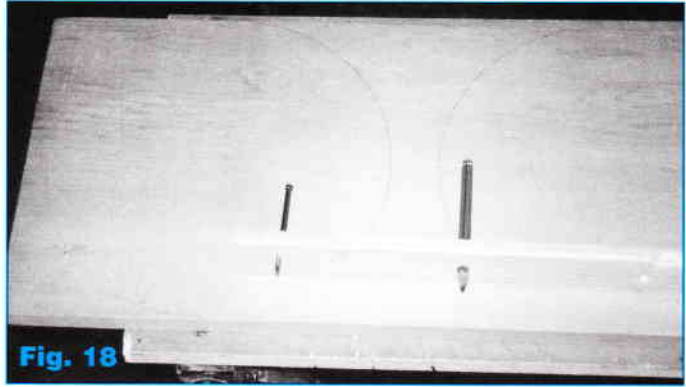

Cut the wheels (J) to shape with a jigsaw (**Fig. 19**) and drill an 1/4" clearance hole through the centre of each wheel for the stub axles.



Clamp both wheels together and sand their edges smooth so they will be identical in size and shape.

18 The coach bolts act as stub axles. If the coach bolts have a square shank below the head, file off the square corners to make them round.

Push the coach bolts through the wheels, then add a large washer between the wheel and the frame sides, a small washer on the other side of the frame, and two nuts to secure the axle. The wheels should be tight. Under the weight of the trolley they will turn okay. If they are too loose, they will flex on the axles and rub on the trolley sides.

19 To cut the bottom angles on the shorter frame sides, lay the trolley on its side and put a straight edge from one wheel back to the rear leg. (**Fig. 20**)



Measure from the bottom of the bottom tray to the straight edge at the wheel and mark the back leg at the same measurement.

Do the same with the other side.

Disassemble the trolley, including the wheels and make these final angle cuts in the table saw mode, against the protractor.

20 Do a final sand of all the components and round over any sharp edges with sandpaper.

21 Reassemble the trolley with glue. Insert the handle (I) from one side. If required, drill a pilot hole and secure it in place with a 40mm nail through the underside edge of the frame side.

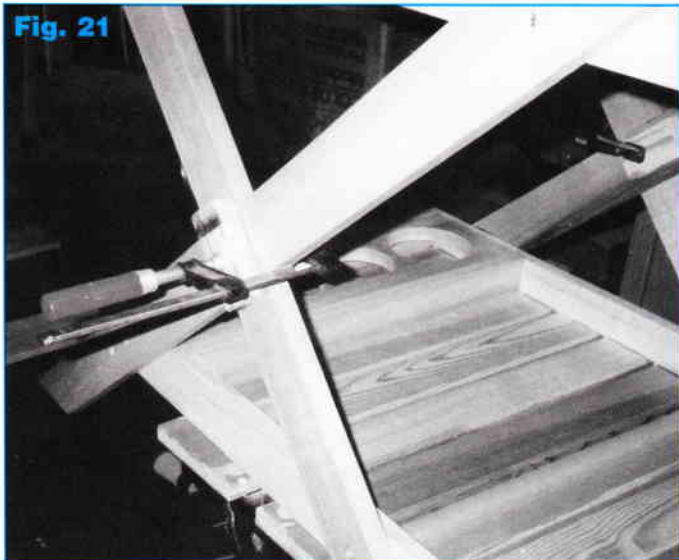

Lay the trays on their side then glue and screw the frame sides in place. The halving joints are glued only, no screws. Turn the trolley over and do the same on the other side. Stand the trolley up and clamp the two halving joints with F or C clamps (Fig. 21).

22 Check the tightness of all screws. Use short lengths of dowel as wood plugs. Alternatively, use a 12.7 mm (1/2") plug cutter to cut 16 wood plugs from a cedar offcut (Fig. 22).



Apply glue to the holes above the 16 counterbored screws and tap home the plugs with a mallet. When the glue is dry, sand the plugs down level (Fig. 23).

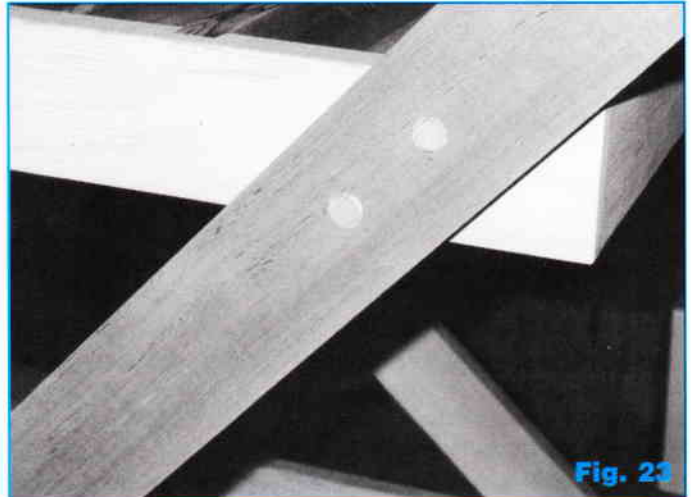

23 Re-attach the wheels and locknuts, then check that the trolley sits level on its wheels and back legs. If necessary, sand or trim the back legs.

24 Dust off and apply the finish of your choice to protect the trolley from the elements.